

Twinklelites TL-2512

Architectural Lighting
Patio Lighting
Deck/Dock Lighting
Recreational Lighting
Stairway/Step Lighting



Nightscaping®
1705 E. Colton Avenue
Redlands, California 92374
Tel: (909) 794-2121
Fax: (909) 794-7292
Help Line: (800) 544-4840
E-mail: info@nightscaping.com
<http://www.nightscaping.com>

Incorporate a festive, twinkling effect into your lighting designs with Nightscaping® brand Twinklelites. Perfect for holiday displays, Twinklelites feature a random on and off blinking pattern that is sure to create visual interest and demand attention in the landscape. Try using longer and multiple strings of Twinklelites to make any commercial or residential space come alive with sparkles flickering through the evening air.

- Lamp Standard** 25 Lamps (Standard)
TL-2512BK -LO659 (Standard 2W Flasher - 50W total per string)
- Strand Length:** 25' of lamps, plus 5' of lead. Custom lengths, lamp spacing or wire color available. Call for quote
- Lamp Spacing:** 12" On-Center
- Material:** **Wire:** #16-2 Black (BK) Stranded
Sockets: Black Noryl™ with phosphor bronze weather-resistant contacts.
- Finish:** TL-2512 BK (Standard)
TL-2512 WH (Optional)
- Socket:** Non-corroding Noryl™ (Wedge Base)
- Mounting:** Mount with ½" #T-25 staples directly to wood.
Mount to trees with nursery tape.

Nightscaping®

Twinklelites

TL-2512



Nightscaping

Optional: See above indications

Accessories:

Clip:	
AC-5050	Adhesive-backed Mini-Clip
MB-605	½" String light Cable Mount Clip
MB-610	1" String light Cable Mount Clip
Mini-Channel:	
5' Mini-Channel without Fascia. White is Standard.	
EA-2012-1, -7, -W (Standard)	
EA-2012-2, -3, -4, -8, -9, -AV, -VP (Optional w/surcharge)	
5' Mini-Channel with Fascia. White is Standard.	
EA-2013-1, -7, -W (Standard)	
EA-2013-2, -3, -4, -8, -9, -AV, -VP (Optional w/surcharge)	

Warranty: 10-year 'repair or replacement' warranty. \Repair de 10 o \warranty..

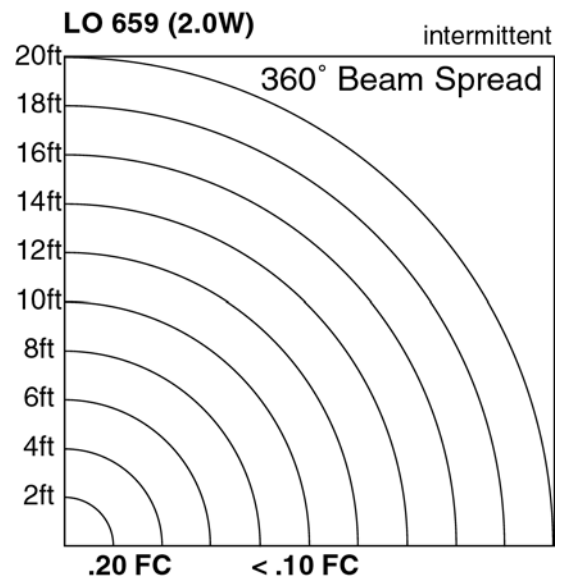
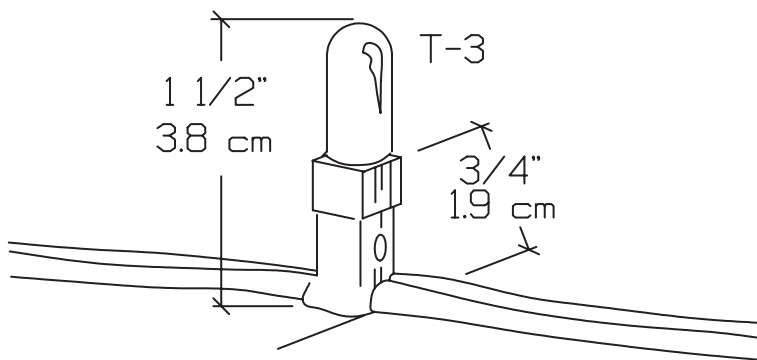

STANDARD LAMP PHOTOMETRIC

DESIGN TIP*

Use in combination with other string lites to maximize twinkle effects.